

DATA SHEET

Product Name Alloy Shunt Resistors

Part Name RA Series

File No. SMD-SP-042

Uniroyal Electronics Global Co., Ltd.

88#, Longteng Road, Economic & Technical Development Zone, Kunshan, Jiangsu, China

Tel +86 512 5763 1411 / 22 /33

Email marketing@uni-royal.cn

Manufacture Plant Uniroyal Electronics Industry Co., Ltd.

Aeon Technology Corporation

Royal Electronic Factory (Thailand) Co., Ltd.

Royal Technology (Thailand) Co., Ltd.

1. Scope

- 1.1 This data sheet is the characteristics of Alloy Shunt Resistors manufactured by UNI-ROYAL.
- 1.2 Electron beam welding.
- 1.3 Ideal for pulse application
- 1.4 RoHS Compliant.
- 1.5 AEC-Q200 qualified.

2. Part No. System

Part No. includes 14 codes shown as below:

2.1 1st~4th codes: Part name. E.g.: RA12,RA20,RA30

2.2 5th~6th codes: Power rating.

Wattage	3	5	7	8	9	10	12	15
Normal Size	3W	5W	7W	8W	9W	AW	CW	FW

2.3 7th code: Tolerance. E.g.: D=±0.5% F=±1% G=±2% G=±2%

2.4 8th~11th codes: Resistance Value.

2.4.1 If value belongs to standard value of E-96 series, the 8th~10th codes are the significant figures of resistance value, and the 11th code is the power of ten.

2.4.2 11th codes listed as following:

0=10⁰ 1=10¹ 2=10² 3=10³ 4=10⁴ 5=10⁵ 6=10⁶ J=10⁻¹ K=10⁻² L=10⁻³ M=10⁻⁴ N=10⁻⁵ P=10⁻⁶

2.5 12th~14th codes.

2.5.1 12th code: Packaging Type. E.g.: T=Tape/Reel

2.5.2 13th code: Standard Packing Quantity.

1=1000pcs 2=2000pcs B=2500 pcs 3=3000pcs

2.5.3 14th code: Special features.

E = Environmental Protection, Lead Free, or Standard type.

3. Ordering Procedure

(Example: RA20 5W ±1% 3mΩ T/R-2500)

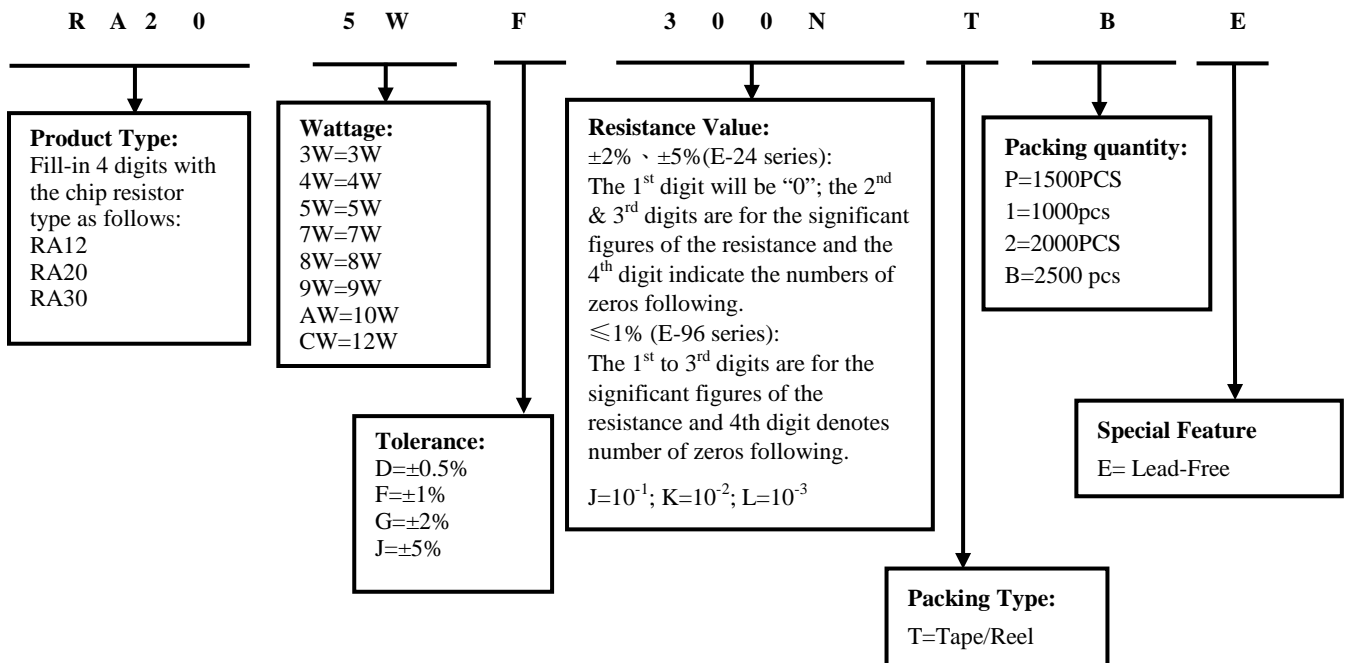

4. Marking

R001 1% → R001: 1mΩ Value 1%: ±1% Tolerance

5. Dimension & Ratings

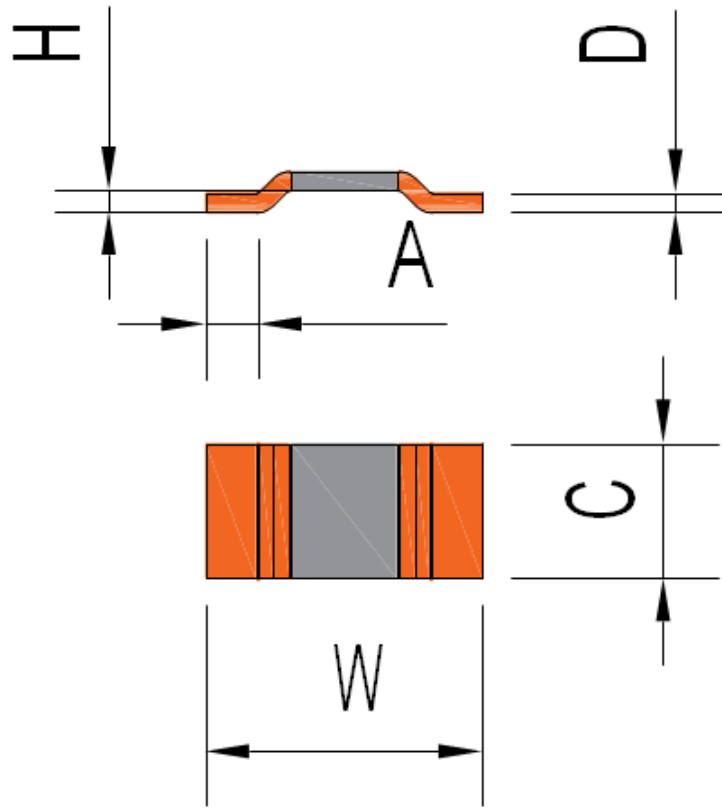

Type	Power Rating	Resistance Range (mΩ)	TCR (ppm/°C)*	D±0.1 (mm)	W (mm)	A (mm)	C (mm)	H (mm)	Tolerance	Operating Temperature
RA12 (2512)	6W	0.2	±175	1.4	6.3±0.2	1.2±0.2	3.1±0.3	0.5±0.1		
	6W	0.3	±175	1.5						
	6W	0.5	±115	0.93						
	5W	1	±100	0.45						
	6W	1.2	±70	1.08						
	5W	1.5	±70	0.86						
	5W	2	±70	0.65						
	4W	2.5	±70	0.5						
	4W	3	±70	0.43						
	3W	4	±70	0.31						
RA20 (3920)	12W	0.2	±200	1.64	10±0.2	2.2±0.2	5.1±0.4	0.5±0.1	±0.5% ±1% ±2% ±5%	-65°C ~170°C
	10W	0.3	±150	1.37						
	9W	0.4	±100	0.97						
	9W	0.5	±70	0.83						
	8W	0.7	±70	0.55						
	7W	1	±50	0.4						
	8W	1	±50	1.16						
	6W	1.5	±50	0.75						
	6W	2	±50	0.56						
	5W	2.5	±50	0.47						
	5W	3	±50	0.37						
	5W	4	±50	0.28						
	4W	5	±50	0.28						
RA30 (5930)	15W	0.1	±200	2.0	15±0.3	4.2±0.3	7.6±0.4	0.5±0.1		
	15W	0.2	±100	1.5						

12W	0.25	±100	1.2					
10W	0.3	±100	0.98					
10W	0.35	±100	0.83					
10W	0.4	±100	0.75					
10W	0.5	±75	0.6					
10W	0.6	±75	0.5					
10W	0.75	±75	0.41					
9W	1	±50	0.86					
8W	1.5	±50	0.61					
7W	2	±50	0.4					
7W	2.5	±50	0.34					
7W	3	±50	0.29					

*TCR (ppm/°C) : Test conditions at 20°C~120°C.

6. Derating Curve

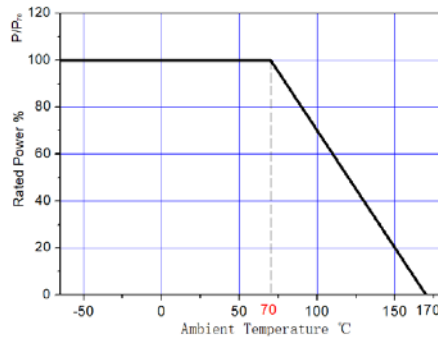

7. Recommended Solder Pad Layout(Unit: mm)

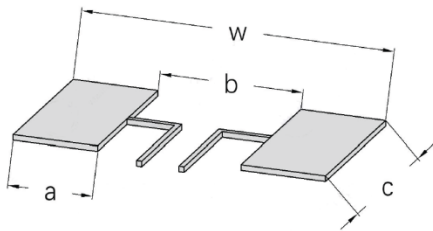

Type	w±0.2	c±0.2	a±0.2	b±0.2
RA12	7	3.4	1.8	3.4
RA20	11	6.2	2.7	5.6
RA30	16	8.75	5.2	5.6

8. Performance Specification

Characteristic	Test Methods	Limits
Dimension	GB/T 5729-1994-4.4.2 Verified according to the specification .	As Spec
High Temperature Exposure	MIL-STD-202 Method 108 1000 hrs. (T=170°C) , unpowered. Measurement at 24±4 hours after test conclusion .	±0.5%
Temperature Cycling	JESD22 Method JA-104 1000 Cycles(-55°C to +155°C) , unpowered. Minimum dwell time 15min. at each temperature extreme. Maximum transition time 1 min. . Measurement at least 24hours after test conclusion .	±0.5%
Humidity Bias	MIL-STD-202 Method 103 1000hrs. (85°C/85%RH) . Note: Specify conditions: 10% of Long-term operating current. Measurement at 24±4 hours after test conclusion .	±0.5%
High Temperature Operating Life	MIL-STD-202 Method 108 1000 hrs.(T=125°C). Long-term operating current was applied to the products intermittently: 90 minutes ON and 30 minutes OFF . Measurement at 24±4 hours after test conclusion .	±0.5%

Resistance to Soldering Heat	MIL-STD-202 Method 210 250°C±5°C, 30s±5s	±0.5%
Solderability	J-STD-002C Steam ageing for 8 hours (93°C); 2) Weld bath temperature 245°C±5°C, duration 5±0.5S .	95% Coverage Min
Vibration	MIL-STD-202 Method 204 20 min.(5 g's) , test from 10Hz-2000 Hz, 12 cycles each of 3 orientations .	±0.5%
Board Flex Test	AEC-Q200-005 REV A, Apply an external force once to the circuit board, bend at least Dx = 2mm, duration 60+5 S .	±0.5%
Terminal Strength (SMD)	AEC-Q200-006 REV A Apply an external force once to the side of the test device, the force is 17.7N (1.8kg), duration 60+1S .	±0.5%
Mechanical Shock	MIL-STD-202H Method 213 1) Pulse waveform: Half-Sine pulse. 2) Accelerate peak: 100g. 3) Pulse duration: 6ms. 4) Orientation & Shock time: ±X, ±Y, ±Z; 3 times each orientation, total 18 times	±0.5%
ESD	AEC-Q200-002 REV-B 1) Direct Contact (DC): ±6kV; 2) Air Discharge (AD): ±12kV, ±16kV, ±25kV;	±0.5%
Resistance to Solvents	MIL-STD-202H Method 215 Note: Add Aqueous wash chemical - OKEM Clean or equivalent. Do not use banned solvents .	There was no missing, faded, smeared, blurred, or shifted (dislodged) with the marks. There was no crack, separation, crazing, swelling, softening, degradation on the samples.
Flame Retardance	AEC-Q200-001 REV B 1) Test current: 100%, 115%, 130%, 150% (rated current). 2) Test duration: 1h.	The temperature is not higher than 350°C for more than 10 seconds, no flame, no explosion.

9. Packing

9.1 Dimension of plastic taping: (Unit: mm)

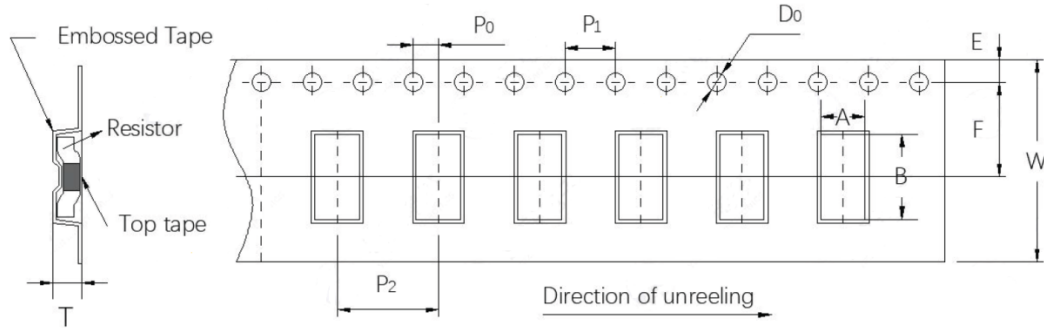

Type	A±0.15	B±0.15	W±0.3	E±0.15	F±0.15	P ₀ ±0.15	P ₁ ±0.15	P ₂ ±0.15	D ₀ ±0.15	T±0.15	*Quantity (pcs)
RA12 0.5~5mΩ	3.5	6.7	12	1.75	5.5	2	4	4	1.50	According to product thickness	3000
RA12 0.2/0.3mΩ	3.7	6.9	16	1.75	7.5	2	4	8	1.50		1000
RA20 0.2~5mΩ	5.8	10.5	24	1.75	11.5	2	4	12	1.50		2500
RA30 0.1mΩ	8.5	15.7	24	1.75	11.5	2	4	12	1.50		1000
RA30 0.2~0.3mΩ	8.5	15.7	24	1.75	11.5	2	4	12	1.50		1500
RA30 0.35~0.5mΩ 1~2mΩ	8.1	15.5	24	1.75	11.5	2	4	12	1.50		2000
RA30 0.6~0.8mΩ 2.5~3mΩ	8.5	15.7	24	1.75	11.5	2	4	12	1.50		2000

*Special quantity

P/N	RA12-0.5	RA12 1.1-1.5	RA20-0.2	RA20-0.3	RA30-0.2
*Quantity (pcs)	2000	2000	2000	1500	1000

9.2 Dimension of Reel : (Unit: mm)

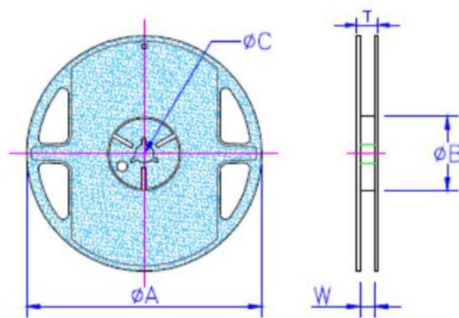

Type	ΦA±0.5	ΦB±0.5	ΦC±0.5	W±0.5	T±0.5
RA12	178	60	13	12.5	21
RA12-0.2 mΩ/0.3 mΩ	203	60	13	16.5	21
RA20	330	100	13	24.5	29
RA30	330	100	13	24.5	29

10. Note

10.1. UNI-ROYAL recommend the storage condition temperature: 15 to 35°C under humidity between 25 to 75%RH (Put condition for individual product). Even under UNI-ROYAL recommended storage condition, solderability of products over 1 year old. (Put condition for each product) may be degraded.

10.2. Store / transport cartons in the correct direction, which is indicated on a carton as a symbol.

Otherwise bent leads may occur due to excessive stress applied when dropping of a carton.

10.3. Product performance and soldered connections may deteriorate if the products are stored in the following places:

- a. Storage in high Electrostatic.
- b. Storage in direct sunshine、rain and snow or condensation.
- c. Where the products are exposed to sea winds or corrosive gases, including Cl₂, H₂S, NH₃, SO₂, NO₂、Br、etc.

11. Record

Version	Description	Page	Date	Amended by	Checked by
1	First version	1~6	Apr.28,2023	Haiyan Chen	Yuhua Xu
2	2.1. Add RA30-0.25/0.3/0.35/0.4/0.6 value of resistance ;	3	Jan.04,2024	Haiyan Chen	Yuhua Xu
	2.2. Modify RA30-0.2 packaging quantity, Change from 1.5K/ disk to 1K/ disk;	5			
	2.3. Modify RA30-0.3 packaging quantity, Change from 2K/ disk to 1.5K/ disk;	5			
	2.4. Modify RA20-0.3 packaging quantity, Change from 2K/ disk to 1.5K/ disk;	5			
	2.5. Modify RA12-1.5 packaging quantity, Modified from 3K/ disk to 2K/ disk;	5			
	2.6. Modify RA12-0.2/0.3 Dimension of Reel, Changed from 7 inches to 8 inches.	5			
3	1. Improve the carrier information of RA30 packaging and correct the carrier size tolerance	6	Jul.15,2024	Junying Ye	Haiyan Chen
	2. Update and modify performance specification	4~5			
	3. Update pad size	4			

© Uniroyal Electronics Global Co., Ltd. All rights reserved. Specification herein will be changed at any time without prior notice